

NOTES: UNLESS OTHERWISE SPECIFIED

1. ALL DIMENSIONAL REQUIREMENTS MUST CONFORM TO TITLE BLOCK TOLERANCES

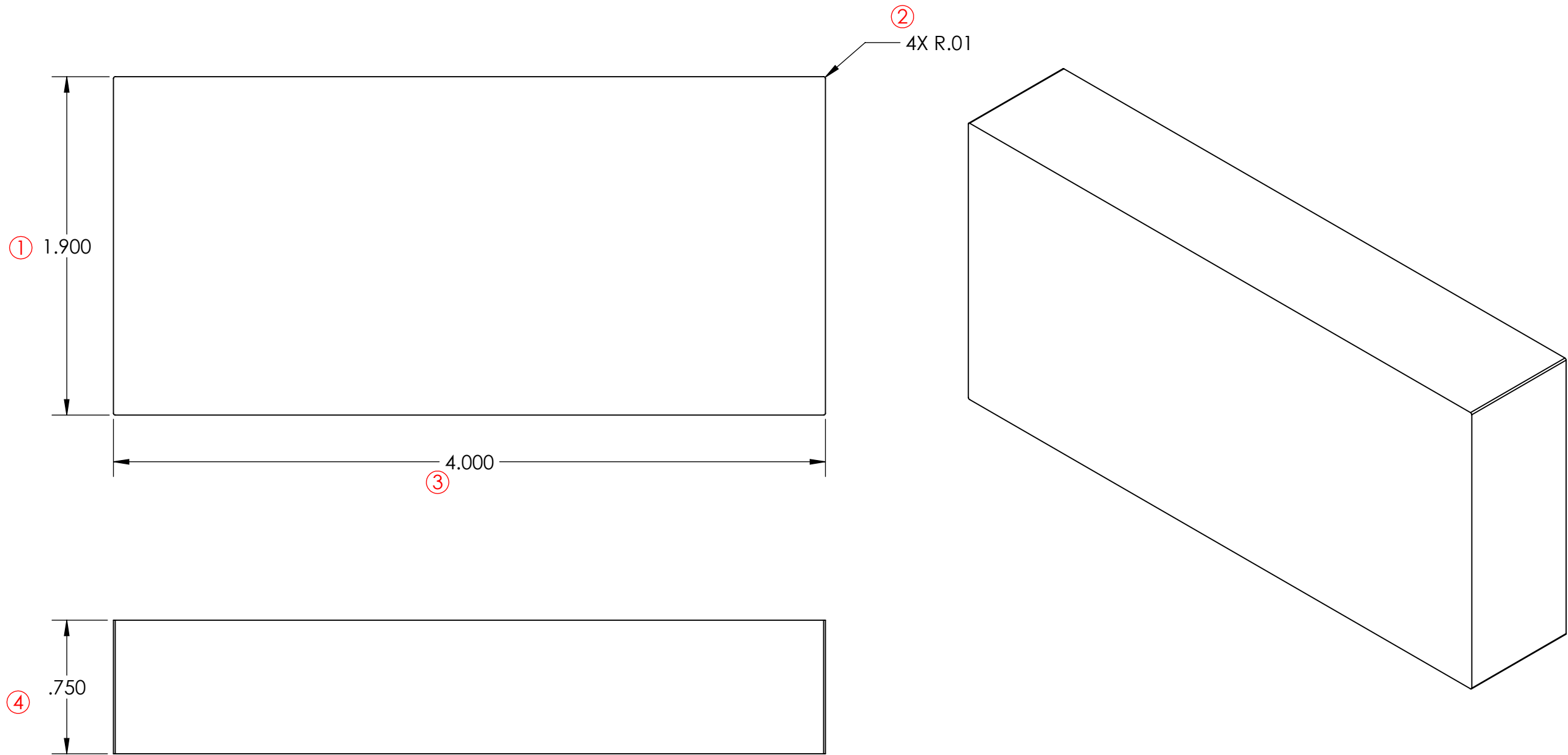

**5** NOTES

UNLESS OTHERWISE SPECIFIED REMOVE ALL BURRS AND BREAK EDGES .020 MAX.  
UNLESS OTHERWISE SPECIFIED, FILLET RADIUS SHALL NOT EXCEED .020  
PART SHALL BE FREE OF OIL, DIRT, CHIPS, RUST, SCALE AND FOREIGN MATTER.

**PROPRIETARY AND CONFIDENTIAL**

ALL SITE CONTENT is the intellectual property of TITANS of CNC: Academy. You have the right to copy and share all materials herein in any medium or format. You may not use materials for commercial purposes and you may not modify or redistribute modified materials. We reserve the right to receive credit for all uses of Content outside of the TITANS of CNC: Academy Site.

DO NOT SCALE DRAWING SCALE: 3:2

MATERIAL :	6061-T6 ALUM
DRAWN	W.BOYCE
CHECKED	
APPROVED	
DIMENSIONS ARE IN INCHES	
TOLERANCES:	ANGLES
X= ± .030	X= ± 1°
XX= ± .010	
XXX= ± .005	

**TITANS**  
*of CNC*

TITLE:	TITAN-1-1M	SIZE	B	8/11/2022	REV	C
				SHEET 1 OF 3		

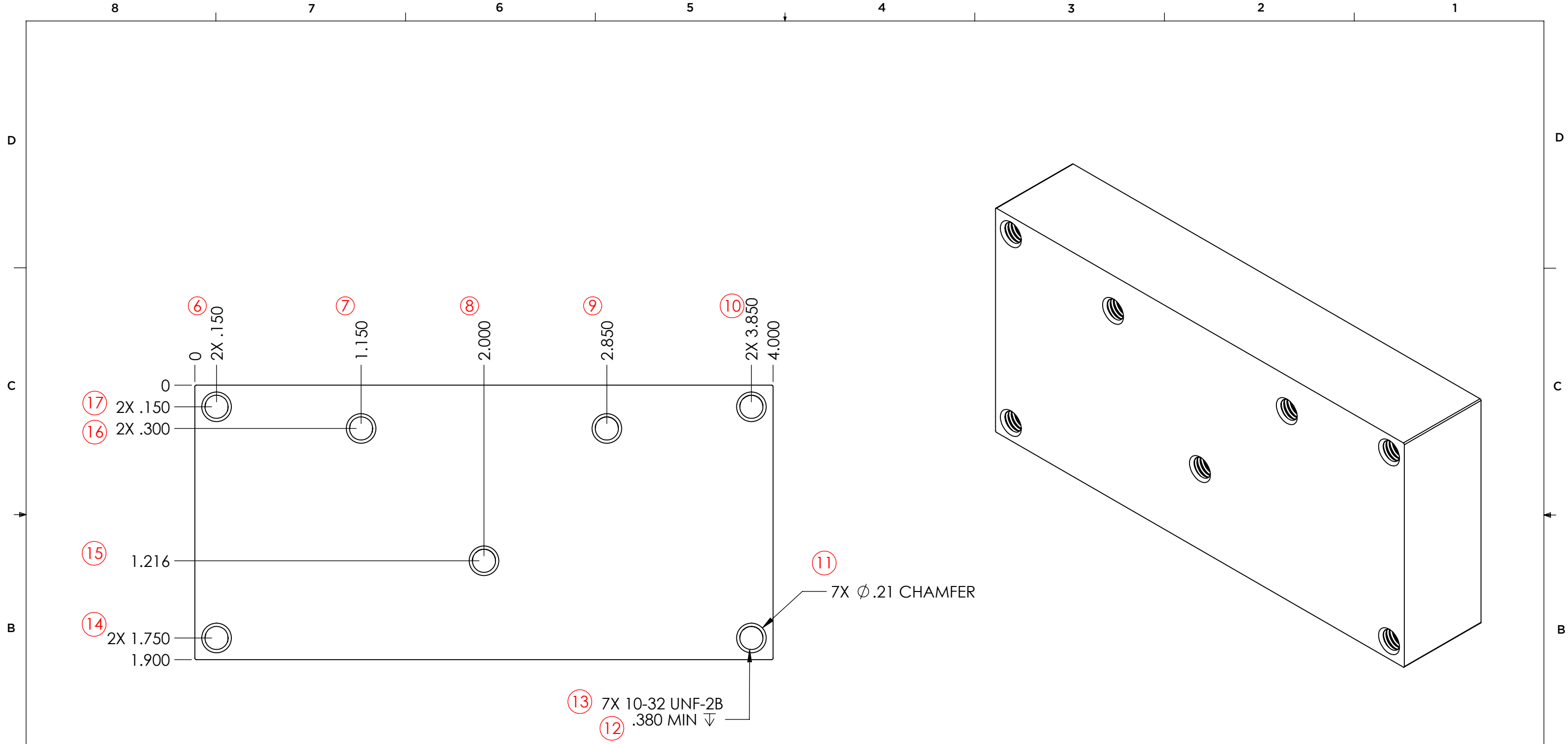

QR Code

DWG. NO.  
**T1M**

**NOTES**

UNLESS OTHERWISE SPECIFIED REMOVE ALL BURRS AND BREAK EDGES .020 MAX.  
UNLESS OTHERWISE SPECIFIED, FILLET RADIUS SHALL NOT EXCEED .020  
PART SHALL BE FREE OF OIL, DIRT, CHIPS, RUST, SCALE AND FOREIGN MATTER.

**PROPRIETARY AND CONFIDENTIAL**

ALL SITE CONTENT is the intellectual property of TITANS of CNC: Academy. You have the right to copy and share all materials herein in any medium or format. You may not use materials for commercial purposes and you may not modify or redistribute modified materials. We reserve the right to receive credit for all uses of Content outside of the TITANS of CNC: Academy Site.

DO NOT SCALE DRAWING

SCALE: 3:2

**MATERIAL :** 6061-T6 ALUM

**DRAWN** W.BOYCE

**CHECKED**

**APPROVED**

**DIMENSIONS ARE IN INCHES**  
**TOLERANCES:** ANGLES  
 X= ± .030 X=± 1°  
 XX= ± .010  
 XXX= ± .005

**TITANS**  
*of CNC*

**TITLE:** TITAN-1-2M

**SIZE** B

8/11/2022  
SHEET 2 OF 3

**REV** C

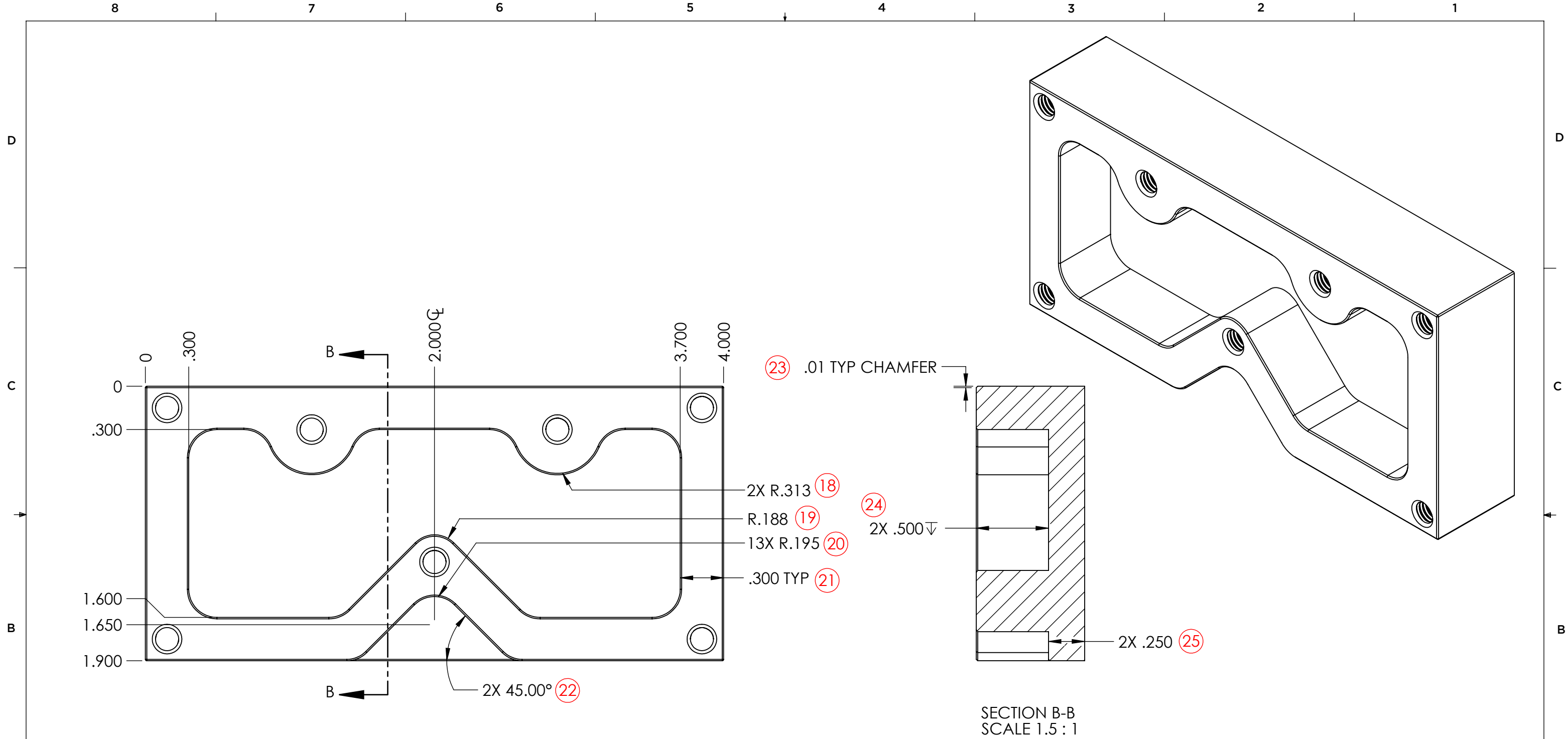

DWG. NO.  
**T1M**

**NOTES**

UNLESS OTHERWISE SPECIFIED REMOVE ALL BURRS AND BREAK EDGES .020 MAX.  
UNLESS OTHERWISE SPECIFIED, FILLET RADIUS SHALL NOT EXCEED .020  
PART SHALL BE FREE OF OIL, DIRT, CHIPS, RUST, SCALE AND FOREIGN MATTER.

**PROPRIETARY AND CONFIDENTIAL**

ALL SITE CONTENT is the intellectual property of TITANS of CNC: Academy. You have the right to copy and share all materials herein in any medium or format. You may not use materials for commercial purposes and you may not modify or redistribute modified materials. We reserve the right to receive credit for all uses of Content outside of the TITANS of CNC: Academy Site.

DO NOT SCALE DRAWING SCALE: 3:2

MATERIAL :	6061-T6 ALUM
DRAWN	W.BOYCE
CHECKED	
APPROVED	
DIMENSIONS ARE IN INCHES	
TOLERANCES:	ANGLES
X= ± .030	X= ± 1°
XX= ± .010	
XXX= ± .005	

# TITANS

## of CNC

TITLE:	TITAN-1-3M	SIZE	B	8/11/2022	REV	C
				SHEET 3 OF 3		