

NOTES: UNLESS OTHERWISE SPECIFIED

1. ALL DIMENSIONAL REQUIREMENTS MUST CONFORM TO TITLE BLOCK TOLERANCES

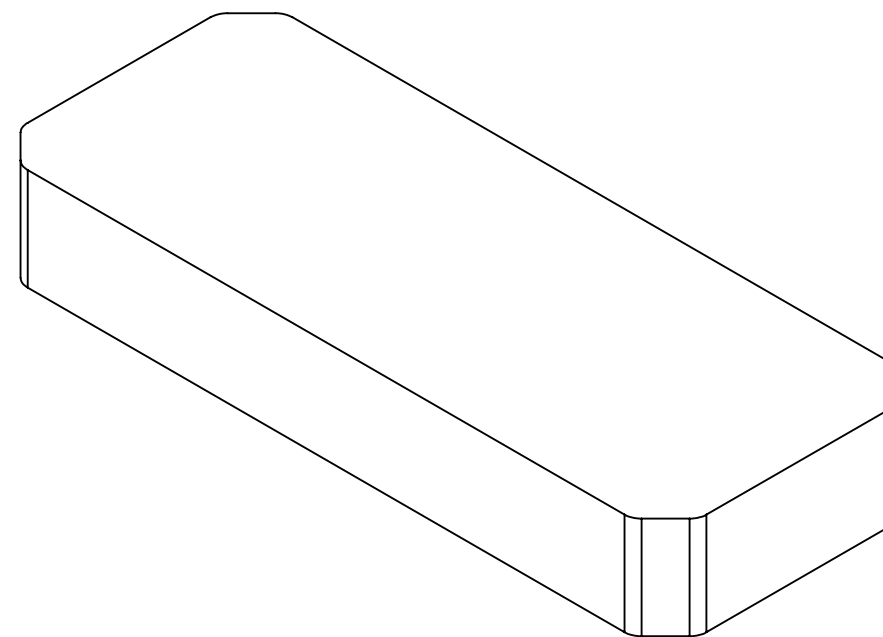
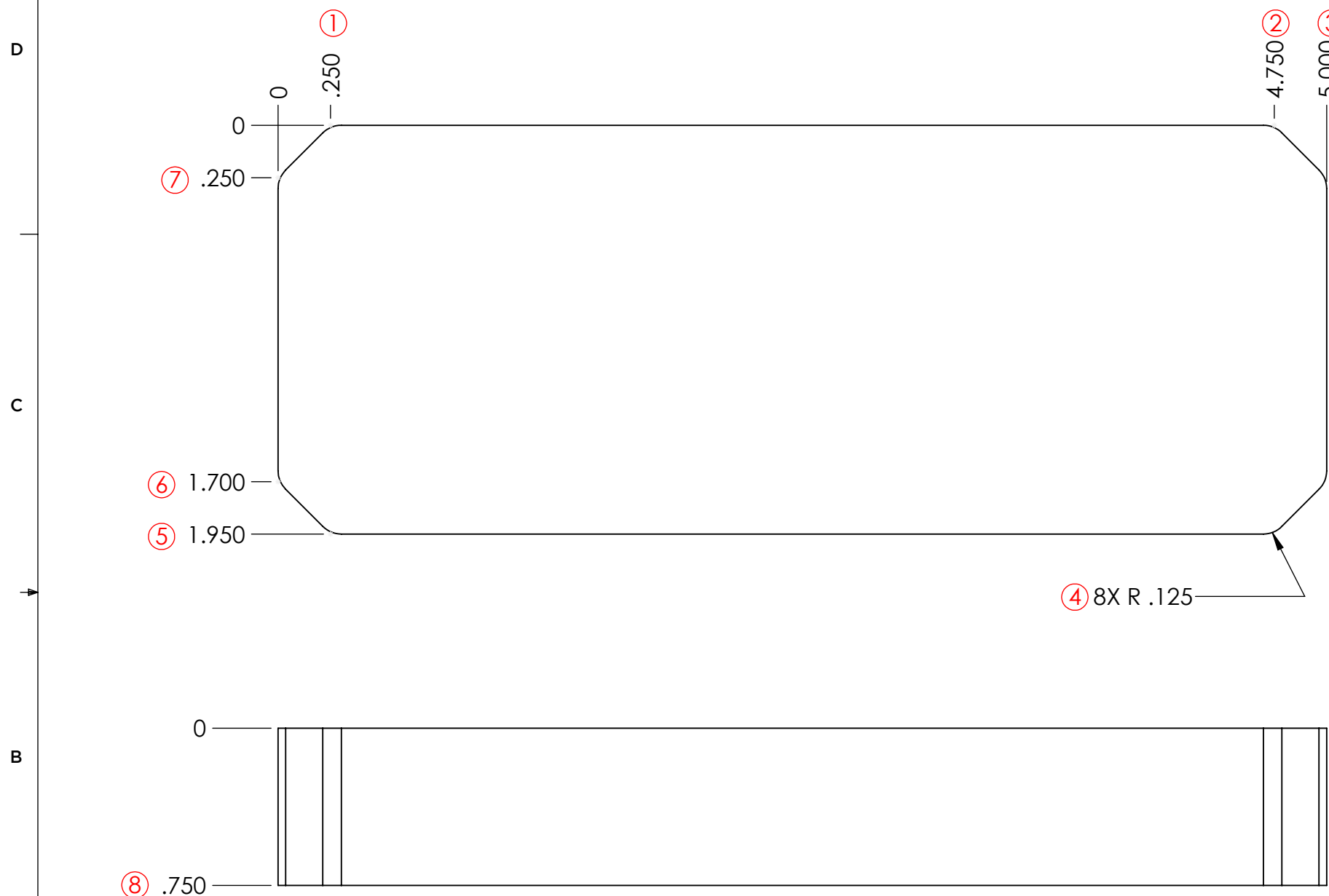

DWG. NO.
T2M

NOTES

UNLESS OTHERWISE SPECIFIED REMOVE ALL BURRS AND BREAK EDGES .020 MAX.
UNLESS OTHERWISE SPECIFIED, FILLET RADIUS SHALL NOT EXCEED .020
PART SHALL BE FREE OF OIL, DIRT, CHIPS, RUST, SCALE AND FOREIGN MATTER.

PROPRIETARY AND CONFIDENTIAL

ALL SITE CONTENT is the intellectual property of TITANS of CNC: Academy. You have the right to copy and share all materials herein in any medium or format. You may not use materials for commercial purposes and you may not modify or redistribute modified materials. We reserve the right to receive credit for all uses of Content outside of the TITANS of CNC: Academy Site.

DO NOT SCALE DRAWING

SCALE: 3:2

MATERIAL : 6061-T6 ALUM

DRAWN W.BOYCE

CHECKED

APPROVED

DIMENSIONS ARE IN INCHES
TOLERANCES: ANGLES
X= ± .030 X= ± 1°
XX= ± .010
XXX= ± .005

TITANS
of CNC

TITLE: TITAN-2-1M

SIZE B 12/21/2022 SHEET 1 OF 3

REV D

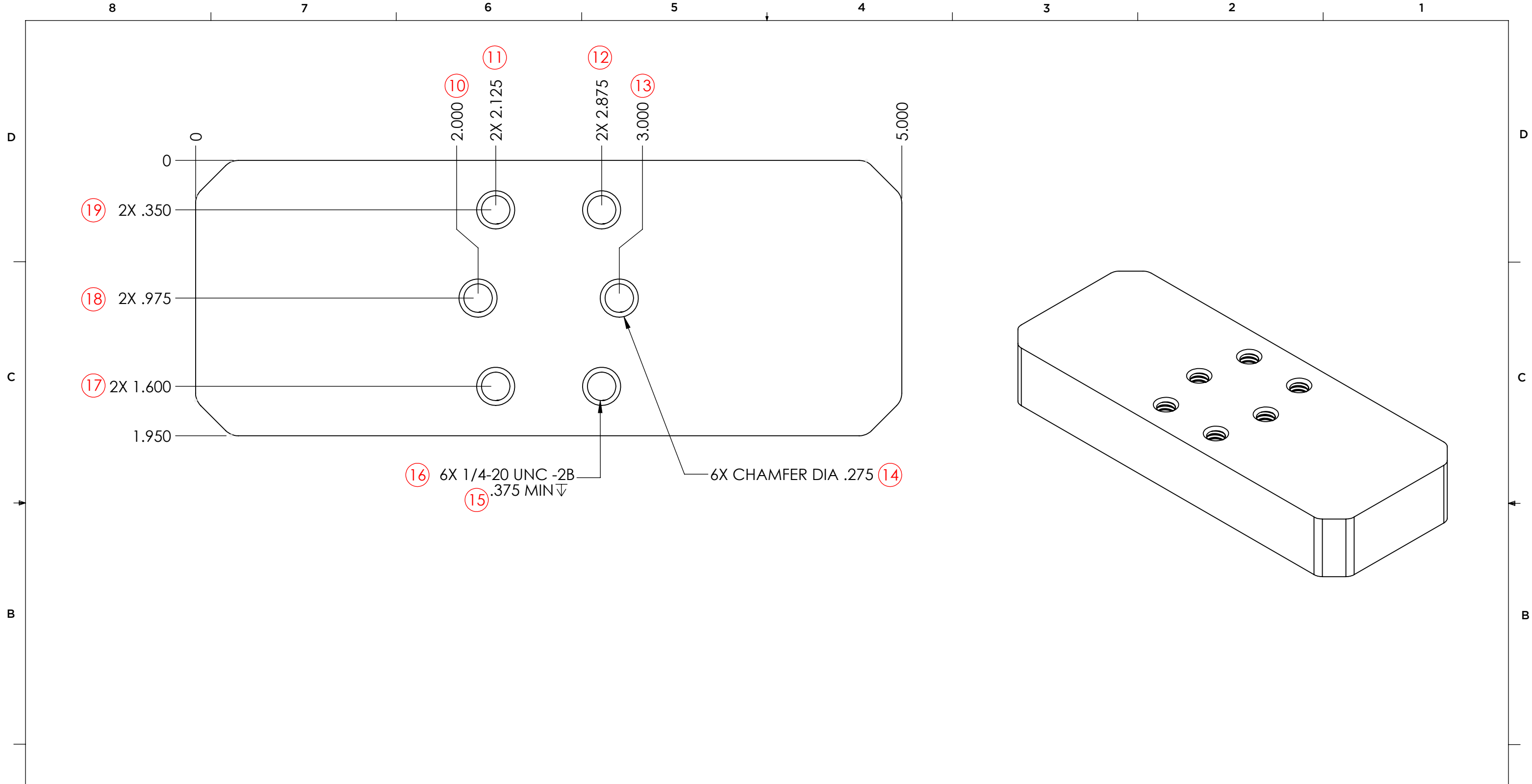

16 6X 1/4-20 UNC -2B
 15 .375 MIN ∇
 14 6X CHAMFER DIA .275



DWG. NO.
T2M

NOTES
 UNLESS OTHERWISE SPECIFIED REMOVE ALL BURRS AND BREAK EDGES .020 MAX.
 UNLESS OTHERWISE SPECIFIED, FILLET RADIUS SHALL NOT EXCEED .020
 PART SHALL BE FREE OF OIL, DIRT, CHIPS, RUST, SCALE AND FOREIGN MATTER.

PROPRIETARY AND CONFIDENTIAL

ALL SITE CONTENT is the intellectual property of TITANS of CNC: Academy. You have the right to copy and share all materials herein in any medium or format. You may not use materials for commercial purposes and you may not modify or redistribute modified materials. We reserve the right to receive credit for all uses of Content outside of the TITANS of CNC: Academy Site.

DO NOT SCALE DRAWING SCALE: 3:2

MATERIAL : 6061-T6 ALUM
 DRAWN W.BOYCE
 CHECKED
 APPROVED

DIMENSIONS ARE IN INCHES
 TOLERANCES: ANGLES
 X= ± .030 X=± 1°
 XX= ± .010
 XXX= ± .005

TITANS of CNC

TITLE: TITAN-2-2M SIZE B

12/21/2022 REV D
SHEET 2 OF 3

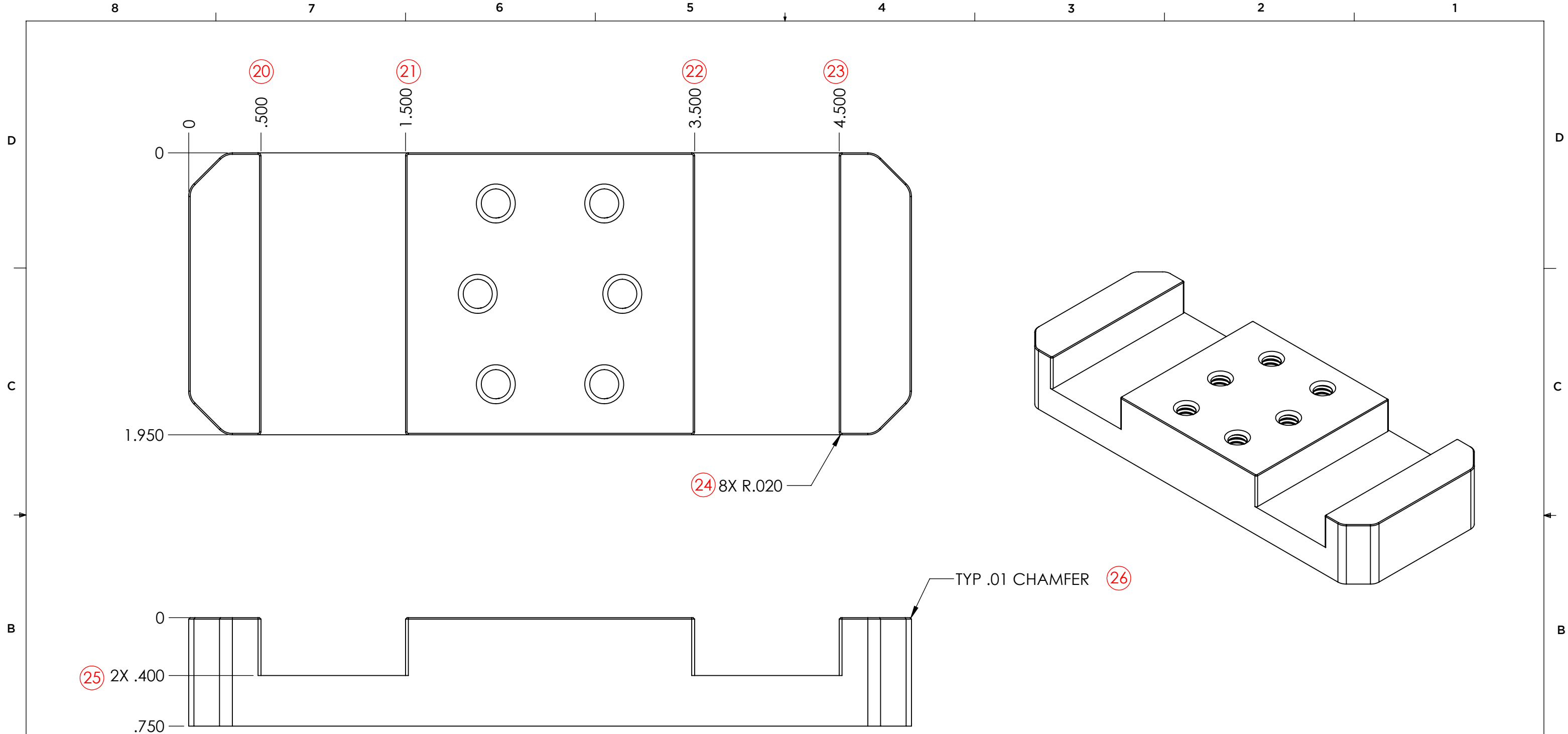

DWG. NO.
T2M

NOTES

UNLESS OTHERWISE SPECIFIED REMOVE ALL BURRS AND BREAK EDGES .020 MAX.
UNLESS OTHERWISE SPECIFIED, FILLET RADIUS SHALL NOT EXCEED .020
PART SHALL BE FREE OF OIL, DIRT, CHIPS, RUST, SCALE AND FOREIGN MATTER.

PROPRIETARY AND CONFIDENTIAL

ALL SITE CONTENT is the intellectual property of TITANS of CNC: Academy. You have the right to copy and share all materials herein in any medium or format. You may not use materials for commercial purposes and you may not modify or redistribute modified materials. We reserve the right to receive credit for all uses of Content outside of the TITANS of CNC: Academy Site.

DO NOT SCALE DRAWING

SCALE: 3:2

MATERIAL : 6061-T6 ALUM

DRAWN W.BOYCE

CHECKED

APPROVED

DIMENSIONS ARE IN INCHES
TOLERANCES: ANGLES
X= ± .030 X= ± 1°
XX= ± .010
XXX= ± .005

TITANS
of CNC

TITLE: TITAN-2-3M

SIZE	12/21/2022	REV
B	SHEET 3 OF 3	D

8 7 6 5 4 3 2 1

8 7 6 5 4 3 2 1

D

D

C

C

B

B

A

A